

# 15SN Series

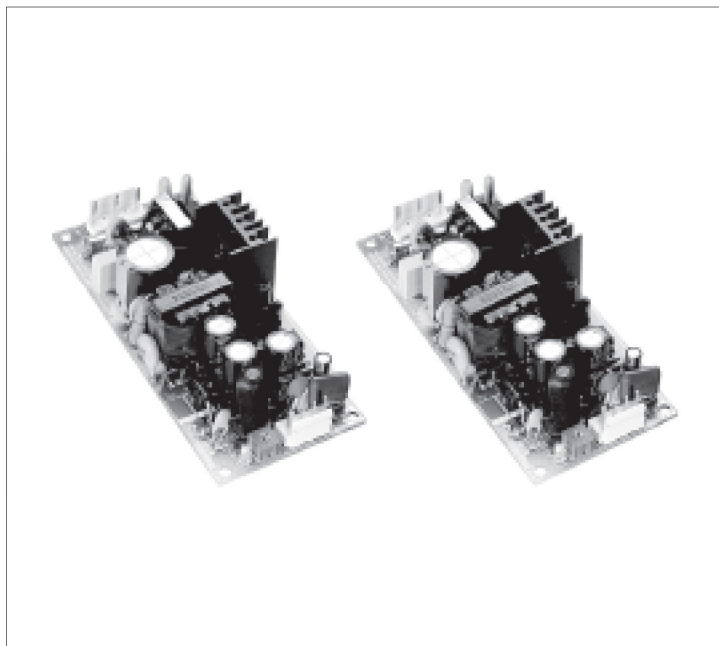

## 15W 1-Channel Non-Cover

- **5V3A/9V1.6A/12V1.2A/15V1A/24V0.6A/36V0.4A/48V0.3A Output**
- **Wide Input Voltage Range (AC85-264V)**
- **Built-in Inrush Current Limiter, Over Current Protector and Over Voltage Protector**
- **Over Temperature Protection**

### SPECIFICATIONS

Item		UP15S05N	UP15S09N	UP15S12N	UP15S15N	UP15S24N	UP15S36N	UP15S48N	
INPUT	VOLTAGE	AC85~264V							0.4A typ (ACIN 110V, Io=100%) 0.2A typ (ACIN 220V, Io=100%)
	FREQUENCY	50/60Hz(47~63Hz)							
	EFFICIENCY	75% Typ	75% Typ	75% Typ	78% Typ	80% Typ	83% Typ	85% Typ	
	INRUSH CURRENT	20A Typ(ACIN 110V, Io=100%) / 40A Typ(ACIN 220V, Io=100%) at cold start							
OUTPUT	VOLTAGE [V]	<b>5</b>	<b>9</b>	<b>12</b>	<b>15</b>	<b>24</b>	<b>36</b>	<b>48</b>	
	CURRENT [A]	<b>3.0</b>	<b>1.6</b>	<b>1.2</b>	<b>1.0</b>	<b>0.6</b>	<b>0.4</b>	<b>0.3</b>	
	LINE REGULATION [mV]	25 Max	45 Max	60 Max	75 Max	120 Max	180 Max	240 Max	
	LOAD REGULATION [mV]	50 Max	90 Max	120 Max	150 Max	240 Max	360 Max	480 Max	
	RIPPLE [mVp-p]	50 Max	90 Max	120 Max	150 Max	240 Max	360 Max	480 Max	
	RIPPLE NOISE [mVp-p]	100 Max	140 Max	170 Max	200 Max	290 Max	410 Max	530 Max	
	TEMPERATURE DRIFT,0-50°C [mV]	50 Max	90 Max	120 Max	150 Max	240 Max	360 Max	480 Max	
	RISE TIME [msec]	100 Max (ACIN 85V, Io=100%)							
HOLDING TIME [msec]	10 Typ (ACIN 85V, Io=100%)								
PROTECTION	OVER CURRENT PROTECTION	Works at over 110% of rating and recovers automatically							
	OVER VOLTAGE PROTECTION	Works at over 115~140% of rating							
ISOLATION	INPUT-OUTPUT	AC3,000V for 1 minute, DC500V 100Mohm (At room temp. & humid.)							
	INPUT-CASE, FG	AC1,500V for 1 minute, DC500V 100Mohm (At room temp. & humid.)							
	OUTPUT-CASE	AC500V for 1 minute, DC500V 100Mohm (At room temp. & humid.)							
ENVIRONMENT	OPERATING TEMP. & HUMID.	0~+50°C, 20~90%RH (Non condensing)							
	STORAGE TEMP. & HUMID.	-20~+75°C, 20~90%RH (Non condensing)							
	VIBRATION	10~55Hz at 1G 3 minutes period, 30 minutes along X, Y and Z axis							
	IMPACT	10G for 20 msec, Once on each X, Y and Z axis							
	APPROVALS								

BLOCK DIAGRAM

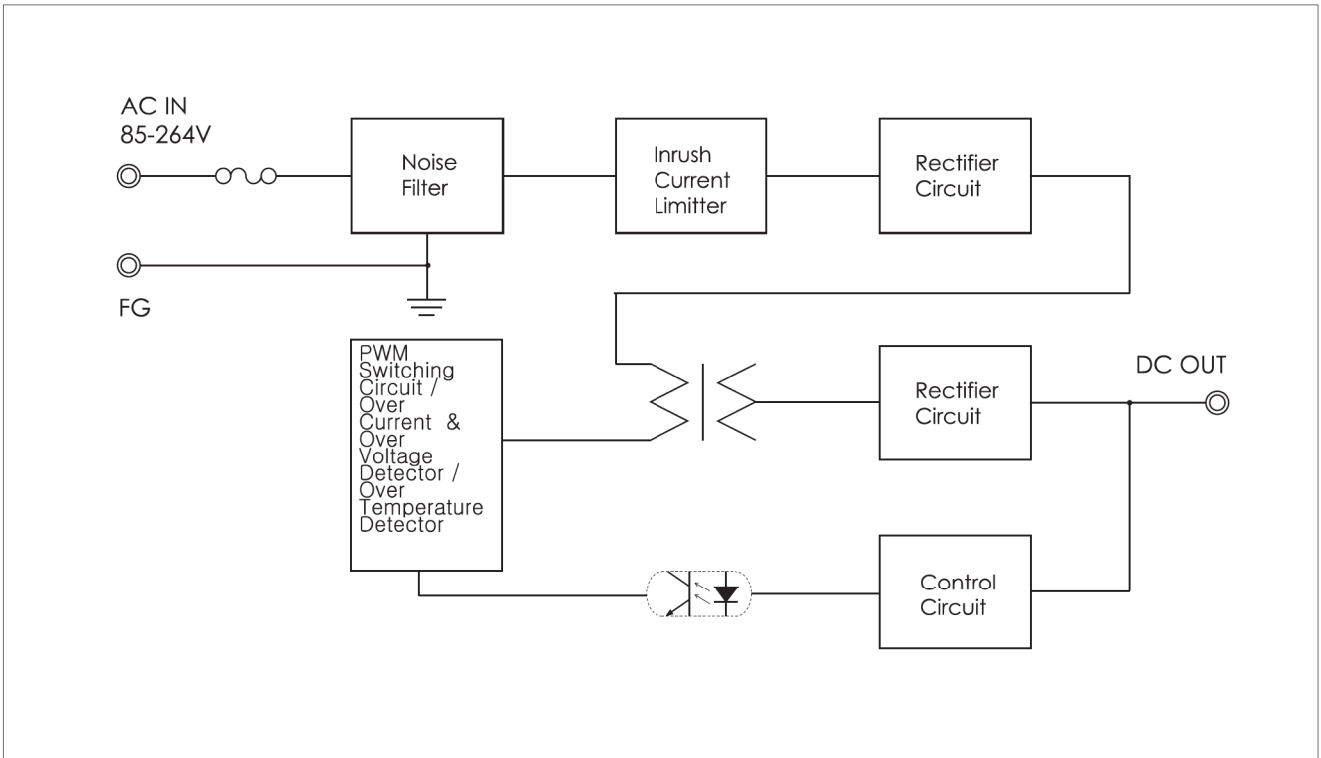

DIMENSIONS(UNITS : MM)

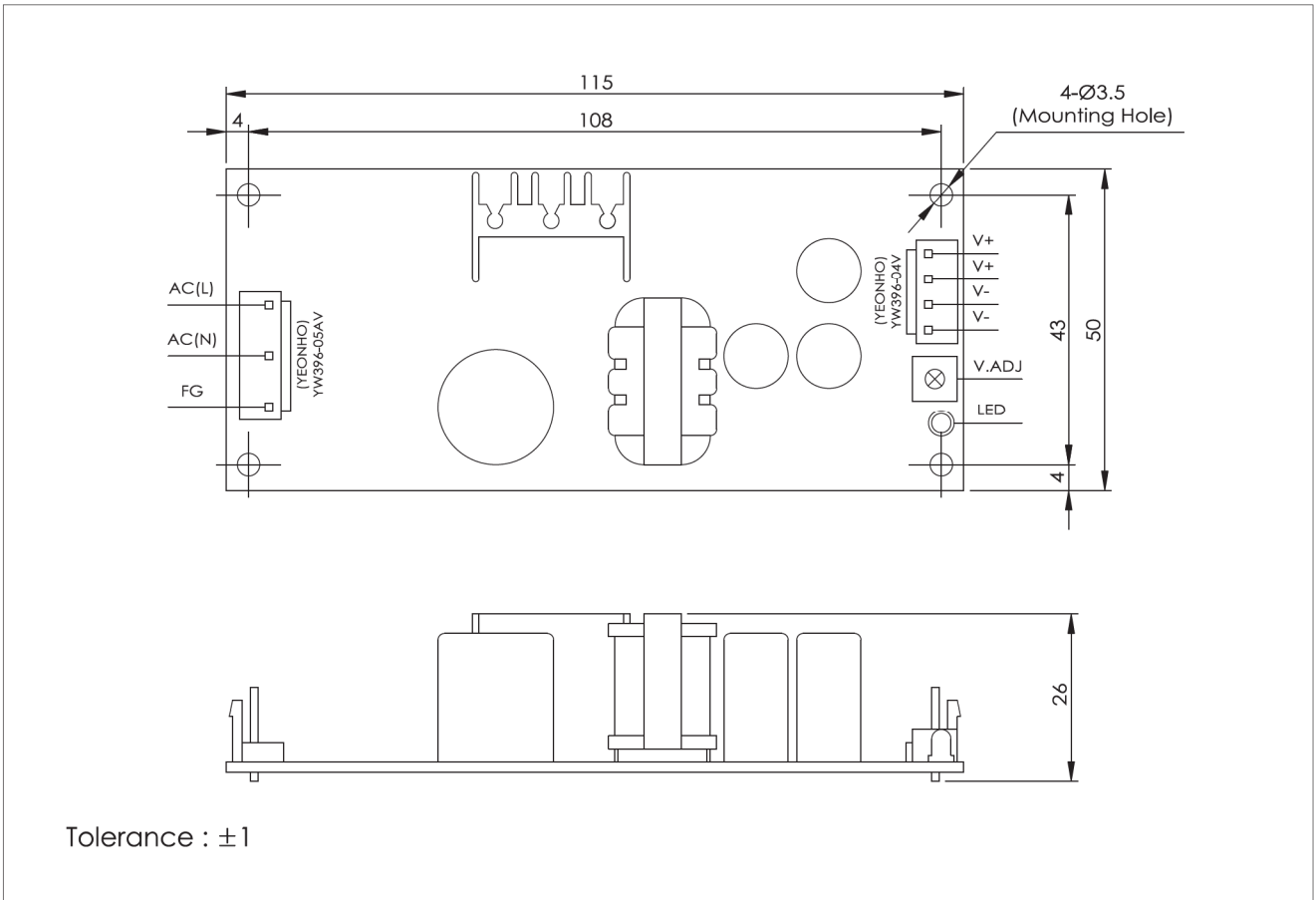

Tolerance : ±1

S.M.P.S