

690P INTEGRATOR

0.75 to 1000kW



DESCRIPTION

The 690+ series is a single range of ac drives designed to meet the requirements of all variable speed applications from single motor speed control through to the most sophisticated integrated multi drive systems.

At the heart of the 690+ is a highly advanced, 32-bit microprocessor based, motor control algorithm, to which can be added a host of control options that allow you to tailor the drive to meet your exact requirements.

The following voltage ranges are available :

- 380-460V three phases from 0.75 to 1000kW
- 380-500V three phases from 2.2 to 110kW
- 220-240V single phases from 0.75 to 2.2kW
- 220-240V three phases from 0.75 to 37kW

OPEN LOOP (V/F), SENSORLESS VECTOR AND CLOSED LOOP VECTOR IN A SINGLE DRIVE POWERS UP TO 355kW

**FUNCTION BLOCK PROGRAMMING
COMMON PROGRAMMING, FIELDBUS AND SOFTWARE TOOLS WITH THE 590+ INTEGRATOR DC SERIES**

DUAL RATED FOR CONSTANT OR QUADRATIC "FAN" TORQUE

INTEGRAL EMC COMPLIANT FILTERS

TECHNICAL SPECIFICATIONS

Power supply - 220-240V ac ($\pm 10\%$) single or three phase; 380-460V ac ($\pm 10\%$) three phase; (500V option available)

Ambient - Constant torque ratings – 0-45°C (40°C with IP40 cover); Quadratic torque ratings – 0-40°C (35°C with IP40 cover); Derate from above temperatures to 50°C max
- Altitude up to 1000m ASL , derate 1% per 100m above 1000m

Overload - Constant torque ratings – 150% for 60 seconds, 180% for 1 second;
Quadratic torque ratings – 115% for 10 seconds

Output frequency - 0-480Hz

Switching Frequency - Frame B 3,6 or 9kHz; F rame C, D, E and F 3 or 6kHz (all with audibly silent switching pattern)

Dynamic Braking - Frame B and C standard; F rame D, E and F optional

Inputs/Outputs

Analogue Inputs - 4 User configurable, 10bit (12 bit with systems expansion module). 0-10V, 0- $\pm 10V$, 0-20mA, 4-20mA

Analogue Outputs- 3 User configurable, 10 bit. 0-10V , 0- $\pm 10V$, 0-20mA, 4-20mA

Digital Inputs - 8 User configurable, nominal 24V dc (30V dc max).

Digital Outputs - 3 User configurable, volt free contact 3A at 230 V ac

Reference Supplies - +10V dc, -10V dc, +24V dc .

Function Block Programming

Function Block Programming allows almost limitless combinations of user functions to be realised with ease. Out of the box the Function Blocks are pre-configured to perform as a standard inverter for immediate use. However by using the programming module or Configed Lite+ software package each function of the drive can be interconnected to any other to perform the required control action.

Function Blocks include :

Value Functions: If, Addition, Difference, Multiplication, Division, Greater than, Less than, Counter, Timer

Logic Functions: Not, And, Nand, Or , Nor, Xor, Trigger, Flip-Flop

Standard Macro's: Basic Speed Control, Forward/Reverse, Raise/Lower, Process PID, Preset Speeds, Closed Loop Speed Feedback, Winder Control

6901 Man Machine Interface

The 6901 Man Machine Interface is used for configuring parametising and controlling the drive. It has been ergonomically designed to provide intuitive access to all functions in a logical menu driven format. Key features include:

- Detachable for 690+ or control panel mounting
- Back lit display
- Multilingual 32 character alphanumeric readout
- Local control of speed, start/stop, jog and direction
- Customized displays and legend
- Password and function lockout
- Quick set up menu

Systems Expansion Module

An optional add-on systems expansion module is available for more advanced applications including phase locking between drives and register control. Key features include:

- 5 Extra configurable digital inputs/outputs
- 4 High resolution (12 bit plus sign) analogue inputs
- 2 Extra encoder inputs
- 2 High speed register mark inputs



TECHNICAL SPECIFICATIONS OF THE CUBICLES (ABOVE 355kW CONSTANT TORQUE)

6-Pulses Drives

Power - At constant torque: 355 to 900 kW ;
variable torque: 400 to 1000 kW
Power supply - 380-460Vac ($\pm 10\%$) three phase
Input circuit breaker - standard
Line chokes - standard to limit current harmonics
Output chokes - standard
Operator station - front-panel mounted 6901 operator station

12-Pulses Drives

Low current harmonic content
Power - At constant torque: 355 to 600 kW ;
variable torque: 400 to 650 kW
Power supply - 380-460Vac ($\pm 10\%$) three phase
Input circuit breaker - standard
Input transformer (not installed in the cubicle) as option - 2 secondary D/Y windings
Output chokes - standard
Operator station - front-panel mounted 6901 operator station

18 Pulses Drives

Current THD as per IEEE 519 (1992)
Power - At constant torque: 630 to 900 kW ;
variable torque: 750 to 1000 kW
Power supply - 380-460Vac ($\pm 10\%$) three phase
Input circuit breaker - standard
Input transformer (not installed in the cubicle) as option - 3 secondary 20° phase-shift windings
Output chokes - standard
Operator station - front-panel mounted 6901 operator station

ENERGY SAVINGS
HIGH RETURN ON INVESTMENT ON HVAC APPLICATIONS
POWER FACTOR IMPROVEMENT
DUAL POWER RATING ON HVAC APPLICATIONS
FLUX VECTOR CONTROL WITH OR WITHOUT SENSOR - V/F CONTROL
REDUCED HARMONIC CONTENT WITH 12 OR 18 PULSE VARIANTS

STANDARDS

The 690P series meets the following standards when installed in accordance with the relevant product manuals

CE marked to (Safety, Low Voltage Directive) EN61800-3 (EMC Compliance) with integral filter

UL listed to US and UL US LISTED listed to Canadian safety standards

690P 4Q POWER SUPPLY

0.75 to 1000kW

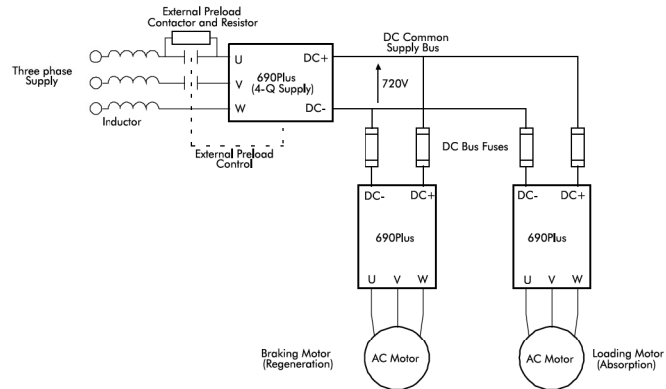
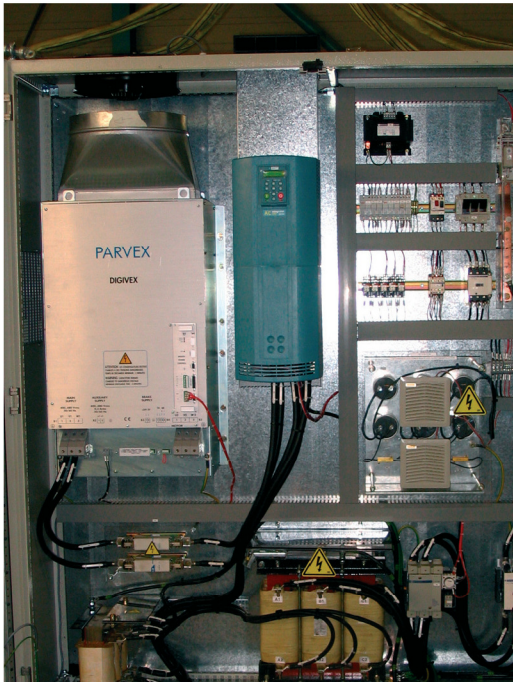

DESCRIPTION

In many section control applications, the power required by the whole machine is lower than the sum of the powers of each section. Indeed, all the sections of the machine are not simultaneously motoring; generally, some motors are driving their load whereas others are regenerating back to their drive.

For such applications, it is advised to link all the drives' dc bus together : the regenerating sections supply the motoring sections, which result in significant energy savings for the system.

Configured as a 4-quadrant power supply, the 690P drives is the ideal power supply for such systems. The power regenerated by the system is not dissipated in braking resistors but fed back to the mains.

The current waveforms are quasi-sinusoidal, which limits the harmonic disturbances of the mains.

ENERGY SAVINGS THANKS TO POWER SHARING ON THE COMMON DC BUS

NO MAINTENANCE (NO BRAKING RESISTOR)

REDUCED TOTAL HARMONIC DISTORTION,

AS PER IEEE 519 LIMITS

HIGH POWER FACTOR ($\cos \varphi \sim 1$)

380-460V (±10%) AC Supply 50/60 Hz Three phase

Type	Frame	Constant Torque Rating		Quadratic Torque Rating		Inductance	Braking Module
		Nominal Power (kW)	Output Current (A)	Nominal Power (kW)	Output Current (A)		
690B-0007-43-xx	B	0.75	2.5	-	-	N/A	Standard
690B-0015-43-xx	B	1.5	4.5	-	-		
690B-0022-43-xx	B	2.2	5.5	-	-		
690B-0040-43-xx	B	4.0	9.5	-	-		
690B-0055-43-xx	B	5.5	12	-	-		
690C-0075-43-xx	C	7.5	16	11	23	Internal standard Inductance on continuous bus	
690C-0110-43-xx	C	11	23	15	31 (UL=27)*		
690C-0150-43-xx	C	15	31	18.5	38		
690D-0180-43-xx	D	18.5	38	22	45		
690D-0220-43-xx	D	22	45	30	59 (UL=52)*	Internal standard Inductance three phase	
690D-0300-43-xx	D	30	59	37	73		
690E-0370-43-xx	E	37	73	45	87		
690E-0450-43-xx	E	45	87	55	105	External Inductance	Option
690F-0550-43-xx	F	55	105	75	145		
690F-0750-43-xx	F	75	145	90	165		
690F-0900-43-xx	F	90	180	110	205		
690G-1100-43-xx	G	110	216	132	260		
690G-1320-43-xx	G	132	250	150	302		
690G-1600-43-xx	G	160	316	180	361		
690G-1800-43-xx	G	180	361	220	420		
690H-2000-43-xx	H	200	375	250	480		
690H-2200-43-xx	H	220	420	250	480		
690H-2500-43-xx	H	250	480	300	545		
690H-2800-43-xx	H	280	520	315	590		
690J-3150-43-xx	J	315	590	355	650	External Inductance	Option
690GM1800-43-xx + 690GS1800-43-xx	K	355	685	400	798		
690HM2200-43-xx + 690HS2200-43-xx	K	400	798	475	912		
690HM2800-43-xx + 690HS2800-43-xx	K	500	988	600	1120		
690JM3150-43-xx + 690JS3150-43-xx	K	600	1120	650	1235		
690GM1800-43-xx + 2 x 690GS1800-43-xx	K	550	1028	630	1197		
690HM2200-43-xx + 2 x 690HS2200-43-xx	K	630	1197	750	1368		
690HM2800-43-xx + 2 x 690HS2800-43-xx	K	800	1482	900	1681		
690JM3150-43-xx + 2 x 690JS3150-43-xx	K	900	1681	1000	1852		

*Max current for UL listing. 3 Phase 230V and 500V 690+ are also available, please refer to your local SSD Parvex sales outlet for details.

380-500V (±10%) AC Supply 50/60 Hz

Type	Frame	Constant Torque rating		Quadratic Torque Rating	
		Nominal Power (kW)	Output Current (A)	Nominal Power (kW)	Output Current (A)
690B-0022-53-xx	B	2.2	5.0	-	-
690B-0040-53-xx	B	4.0	8.0	-	-
690B-0055-53-xx	B	5.5	11	-	-
690C-0055-53-xx	C	5.5	10	7.5	12.5
690C-0075-53-xx	C	7.5	12.5	11	18
690C-0110-53-xx	C	11	18	15	24
690C-0150-53-xx	C	15	27	18.5	30
690D-0180-53-xx	D	18.5	30	22	34
690D-0220-53-xx	D	22	34	30	45
690D-0300-53-xx	D	30	52	37	65
690E-0370-53-xx	E	37	55	45	66
690E-0450-53-xx	E	45	66	55	80
690F-0550-53-xx	F	55	100	75	125
690F-0750-53-xx	F	75	125	90	156
690F-0900-53-xx	F	90	156	110	180

220-240V (±10%) AC Supply 50/60 Hz

Type	Phase Number	Frame	Constant Torque rating		Quadratic Torque Rating		Inductance	Braking Module
			Nominal Power (kW)	Output Current (A)	Nominal Power (kW)	Output Current (A)		
690B-0007-21-xx	1	B	0.75	4.0	-	-	N/A	Standard
690B-0015-21-xx	1	B	1.5	7.0	-	-		
690B-0022-21-xx	1	B	2.2	10.5	-	-		
690B-0007-23-xx	3	B	0.75	4.0	-	-		
690B-0015-23-xx	3	B	1.5	7.0	-	-		
690B-0022-23-xx	3	C	2.2	10.5	-	-		
690B-0040-23-xx	3	C	4.0	16.5	-	-	Internal standard Inductance on continuous bus	Option
690C-0055-23-xx	3	C	5.5	22	7.5	28		
690C-0075-23-xx	3	C	7.5	28	11	42		
690D-0110-23-xx	3	D	11	42	15	54		
690D-0150-23-xx	3	D	15	54	18.5	68		
690D-0180-23-xx	3	D	18.5	68	n.a.	n.a.		
690E-0220-23-xx	3	E	22	80	30	104		
690F-0300-23-xx	3	F	30	104	37	130		
690F-0370-23-xx	3	F	37	130	45	154		
690F-0450-23-xx	3	F	45	154	55	192		

Powers given for 230Vac Supply Voltage

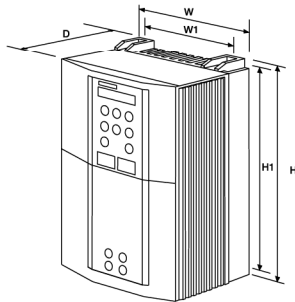

Frame B ,C,D ,E,F

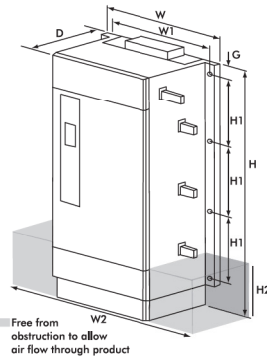

Frame G ,H,J

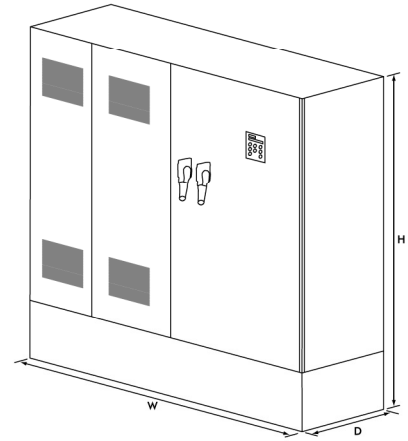

Frame K

Dimensions

Model	Overall Dimensions (mm)				Fixing Centre (mm)					Weight (kg)
	H no brake	H with brake	W	D	W2	H2	H1	W1	G	
Frame B	233	233	177	181	-	-	223	130	-	4.3
Frame C	348	348	201	208	-	-	335	150	-	9.3
Frame D	453	453	252	245	-	-	440	150	-	17.4
Frame E	669	669	257	312	-	-	630	150	-	32.5
Frame F	720	720	257	349	-	-	700	150	-	41.0
Frame G	1042	1490	455	465	675	225	300	420	16	108
Frame H	1177	1750	570	465	805	360	300	536	16	138
Frame J	1288	1825	675	465	825	333	300	641	16	170
Frame K 355/400kW*	2000	2000	1600	600	-	-	-	-	-	-
Frame K 400/475kW*	2000	2000	1600	600	-	-	-	-	-	-
Frame K 500/600kW*	2000	2000	1600	600	-	-	-	-	-	-
Frame K 600/650kW*	2000	2000	2000	600	-	-	-	-	-	-
Frame K 550/630kW*	2000	2000	2400	600	-	-	-	-	-	-
Frame K 630/750kW*	2000	2000	2400	600	-	-	-	-	-	-
Frame K 800/900kW*	2000	2000	2400	600	-	-	-	-	-	-
Frame K 900/1000kW*	2000	2000	3000	600	-	-	-	-	-	-

Options

6901 Programming/Control Module

6052 Remote mounting bezel and 3m lead

Fieldbus Interface	690B	690C-K
PROFIBUS	6053/PROF/00	6055/PROF/00
DeviceNet	6053/DNET/00	6055/DNET/00
Modbus Plus	6053/MBP/00	6055/MBP/00
Ethernet	6053/ETH/00	6055/ETH/00
CANopen	6053/CAN/00	6055/CAN/00
Modbus/RS422/RS485/EIBisynch	6053/EI00/00	6055/EI00/00
ControlNet	6053/CNET/00	6055/CNET/00
Link	6053/LINK/00	6055/LINK/00
LonWorks	6053/LON/00	6055/LON/00
Encoder feedback	AH467407 U001 (Carte)	6054/HTTL

Wall Mount IP40 Covers	
	LA467452 (Taille B)
	LA465034U002 (Taille C)
	LA465048U002 (Taille D)
	LA465058U002 (Taille E)

System Expansion Module

ConfigEd Lite+ 'Windows' graphical configuration software (see page 145)

Optional external EMC filters and line chokes please refer to pages 137-138-139-141

Details on brake resistors please refer to page 132