

Linear Measuring Technology

Draw wire mechanics with encoder or analogue sensor

Draw wire encoder D135



Wide temperature-range



Shock/vibration resistant



High IP protection rating



Reverse polarity protection

Robust

- **Insensitive to the environment**
Titanium-anodised aluminium housing
- **High-resistance wire**
Stainless steel wire
- **Wire exit free from wear**
Diamond-polished ceramic guide
- **Can be used in a wide temperature range without extra charge**
max. -20 +90 °C



Versatile

- **Suitable for various sensors/encoders**
 - Absolute
 - Fieldbus
 - Incremental
 - Analogue
- **Flexible Mounting**
Various fastening possibilities are available
- **Flexible connection possibilities**
Cable, connector, radial, axial
- **Linearity up to 0.05 %**

Dynamic

- **High traverse speed**
- **High acceleration**
Dynamic spring traction by means of a constant force spring, long service life, approx. 2 million complete cycles

Mechanical characteristics (draw wire mechanics):

Measuring range:	8000 mm	10000/15000 mm	20000 mm	25000/30000 mm	35000/40000 mm
Extension force Fmin:	7.2 N	8.7 N	7.0N	7.3 N	7.0 N
Fmax:	16.0 N	16.9 N	12.4 N	15.7 N	14.1 N
Max. speed:	10 m/s	6m/s	5m/s	5 m/s	5 m/s
Max. acceleration:	140 m/s ²	80 m/s ²	60 m/s ²	60 m/s ²	60 m/s ²
Linearity:	analogue output: 0.1 % (of the measuring range) encoder: 0.05 % (of the measuring range)				
Weight:	depending on the measuring range and on the sensor/encoder used				
Materials:	housing: titanium-anodised aluminium wire: stainless steel \varnothing 0.5 mm				
Protection (sensor):	IP65 (IP67 on request for encoders)				
Lifetime	> 2 million full cycles				

Operating principle::

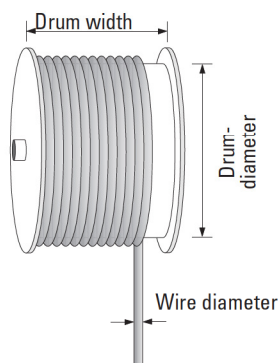

Construction:

The core of a draw wire device is a drum mounted on bearings, onto which a wire is wound. Winding takes place via a spring-loaded device.

Note

Exceeding the maximum extension length of the draw wire will lead to damage to the wire and the mechanics.

Linear Measuring Technology

Draw wire mechanics with encoder or analogue sensor

Draw wire encoder D135

Electrical characteristics (digital output):

The electrical characteristics of the draw wire mechanics with digital output can be found in the data sheets of the encoders.

Electrical characteristics (analogue output):

Analogue output:	0 ... 10 V	4 ... 20 mA	Potentiometer
Output:	0 ... 10 V galvanically isolated, 4 conductors	4 ... 20 mA 2 conductors	1 kOhm
Supply voltage:	12 ... 30 V DC	12 ... 30 V DC	max. 30 V DC
Recommended slider current:	–	–	< 1 µA
Max. current consumption:	22.5 mA (no load)	50 mA	–
Reverse polarity protection:	yes	yes	–
Operating temperature:	-20 ... +60 °C	-20 ... +60 °C	-20 ... +85 °C

Connection diagrams:

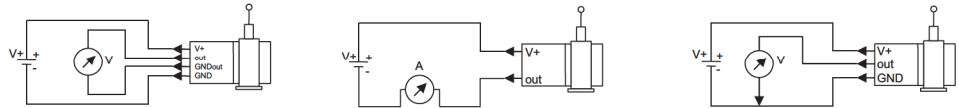

CE compliant according to: EN 61000-6-2, EN 61000-6-4, EN 61000-6-3

Terminal assignment (analogue output):

Pin	Cable colour	0 ... 10 V	4 ... 20 mA	1 kOhm
1	brown	V+	V+	V+
2	white	Signal	n. c.	Slider
3	blue	GND	Signal	GND
4	black	GND Sig.	n. c.	n. c.

Connector (analogue output):

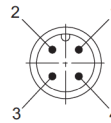

Dimensions:

Draw wire mechanics with encoder, measuring range 8000 mm

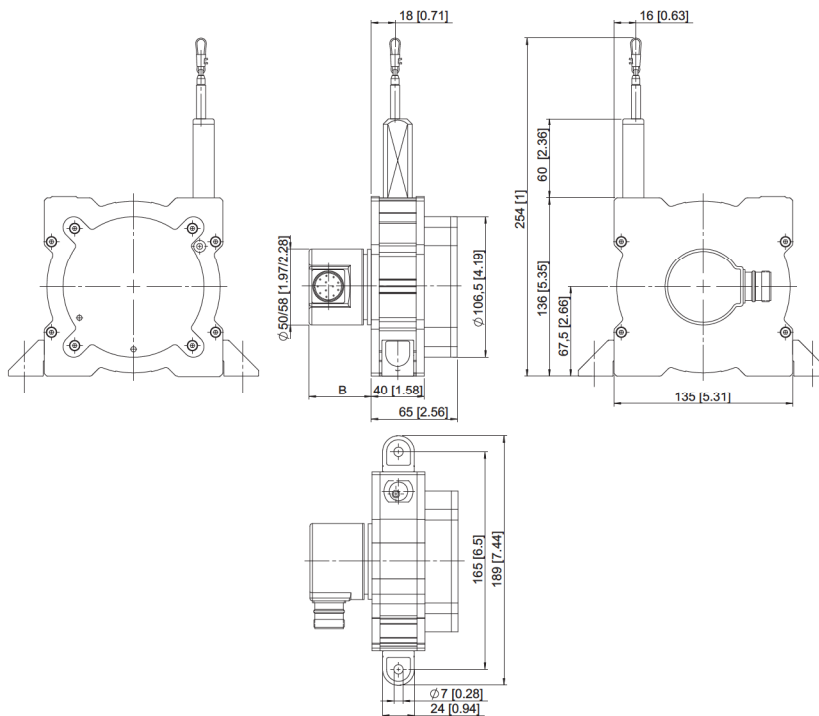

Dimension B depends on the encoder used	
Encoder	B
Sendix incremental (5000) D8.4D1.XXXX.00XX.XXXX	37.00
Sendix absolut (5863) D8.4D1.XXXX.63XX.XXXX	49.50
Sendix absolut (5868) D8.4D1.XXXX.68XX.XXX	76.00

Linear Measuring Technology

Draw wire mechanics with encoder or analogue sensor

Draw wire encoder D135

Dimensions:

Draw wire mechanics with encoder, measuring range 10000 mm ... 20000 mm

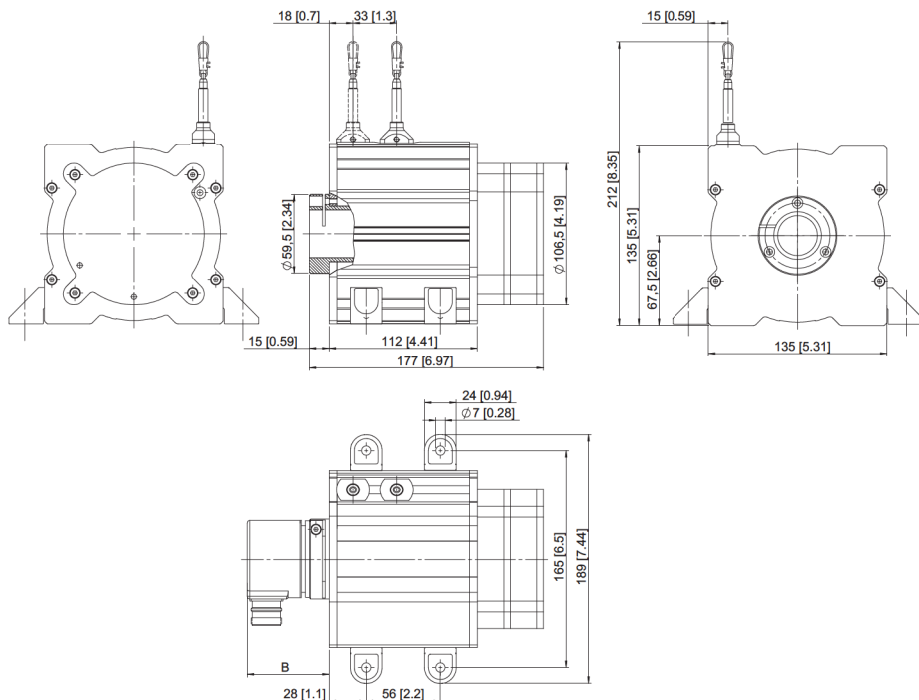

Dimension B depends on the encoder used	
Encoder	B
Sendix incremental (5000) D8.4D1.XXXX.00XX.XXXX	37.00
Sendix absolut (5863) D8.4D1.XXXX.63XX.XXXX	49.50
Sendix absolut (5868) D8.4D1.XXXX.68XX.XXXX	76.00

Dimensions:

Draw wire mechanics with encoder, measuring range 25000 mm ... 40000 mm

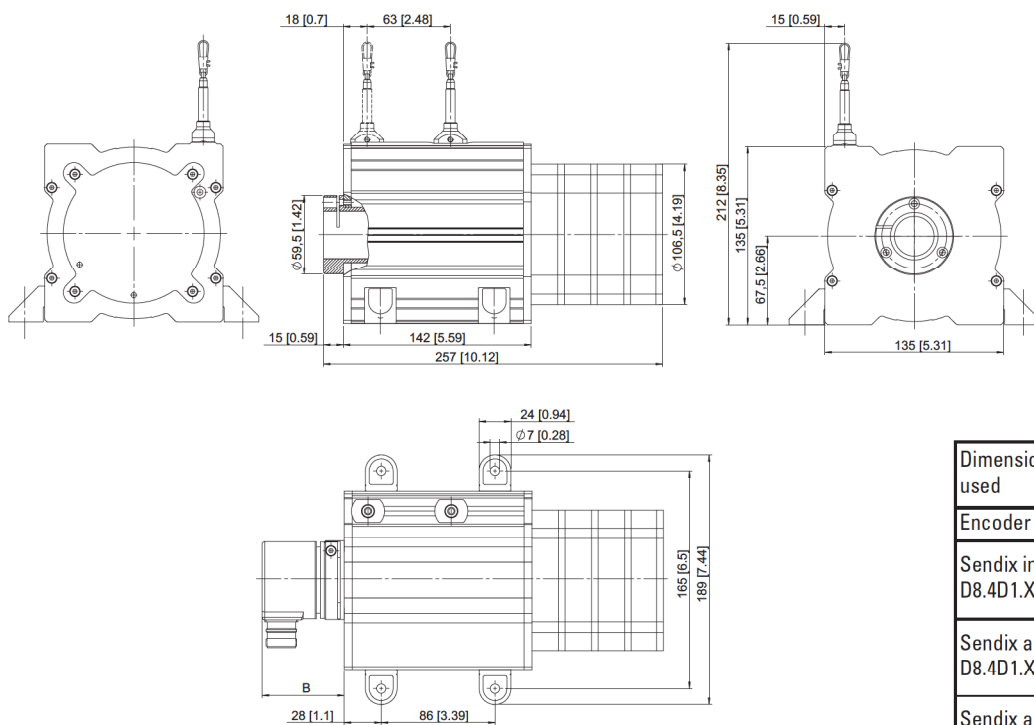

Dimension B depends on the encoder used	
Encoder	B
Sendix incremental (5000) D8.4D1.XXXX.00XX.XXXX	37.00
Sendix absolut (5863) D8.4D1.XXXX.63XX.XXXX	49.50
Sendix absolut (5868) D8.4D1.XXXX.68XX.XXXX	76.00

Linear Measuring Technology

Draw wire mechanics with encoder or analogue sensor

Draw wire encoder D135

Order code with encoder:

D8.4D1.XXXX.XXXX.XXXX

Draw wire mechanics

Measuring range*

- 0800 = 8 000 mm
- 1000 = 10 000 mm
- 1500 = 15 000 mm
- 2000 = 20 000 mm
- 2500 = 25 000 mm
- 3000 = 30 000 mm
- 3500 = 35 000 mm
- 4000 = 40 000 mm

*other measuring ranges on request

Resolution/protocol/options
depending on the encoder used

Type of connection:*
depending on the encoder used

Output*
depending on the encoder used

Encoder used*
00 = Sendix incremental 5000
63 = Sendix absolut 5863
68 = Sendix absolut 5868

*You will find our recommended encoders below

Standard resolutions for draw wire with incremental encoder Sendix 5000, drum circumference 333.33 mm (357.14 mm for the 8 000 mm measuring range)		
Pulses/revolution	500	2000
Pulses/mm	1.5 (1.4)	6 (5.6)
Resolution [mm]	0.66 (0.71)	0.17 (0.18)

Standard resolutions for draw wire with absolute encoder Sendix 5863 or 5868, drum circumference 333.33 mm (357.14 mm for the 8 000 mm measuring range)		
Absolute encoder	5863	5868
Pulses/revolution	2048/ 11 bits	4096, programmable via the bus/ 12 bits
Pulses/mm	6.14 (5.73)	12.28 (11.47)
Resolution [mm]	~0.16 (0.17)	~0.08 (0.09)

Recommended standard device with incremental encoder
Sendix 5000:

D8.4D1.XXXX.0053.2000

The standard device is supplied mounted. The mounted encoder is the Sendix incremental 5000 encoder, Connector axial 8 pin M12, Push-pull with inverted signals, supply voltage 10 ... 30 V DC (8.5000.8353.2000)

Recommended standard device with absolute encoder
Sendix 5863 or 5868:

D8.4D1.XXXX.6324.G123

Sendix absolut 5863 encoder with **SSI interface** (Gray code), 2048 pulses/rev., Set key, 10 ... 30 V DC, radial 12 pole M23 connector (8.5863.1224.G123)

D8.4D1.XXXX.6822.2113

Sendix absolut 5868 encoder with **CANopen interface**, 4096 pulses/rev. programmable via the bus, Set key, 10 ... 30 V DC, M12 connector (8.5868.1222.2113)

D8.4D1.XXXX.6832.3113

Sendix absolut 5868 encoder with **Profibus connection**, 4096 pulses/rev. programmable via the bus, Set key, 10 ... 30 V DC, M12 connector (8.5868.1232.3113)

Measuring range*

- 0800 = 8 000 mm
- 1000 = 10 000 mm
- 1500 = 15 000 mm
- 2000 = 20 000 mm
- 2500 = 25 000 mm
- 3000 = 30 000 mm
- 3500 = 35 000 mm
- 4000 = 40 000 mm

*other measuring ranges on request

NEW

Linear Measuring Technology

Draw wire mechanics with encoder or analogue sensor



Draw wire encoder D135

Dimensions:

Draw wire mechanics with analogue sensor, measuring range 8000 mm

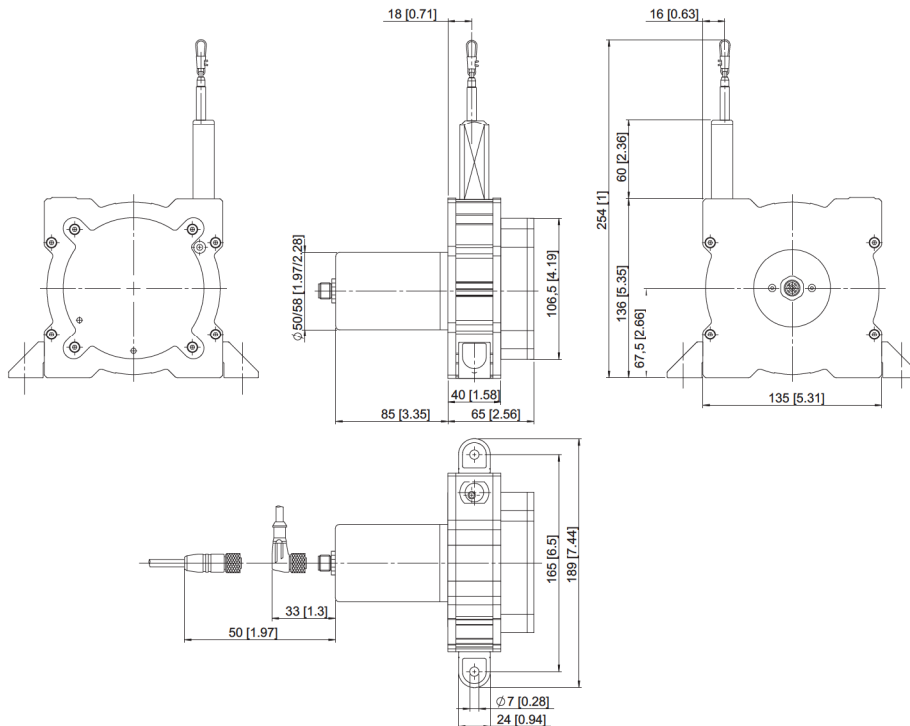

Dimensions:

Draw wire mechanics with analogue sensor, measuring range 10000 ... 20000 mm

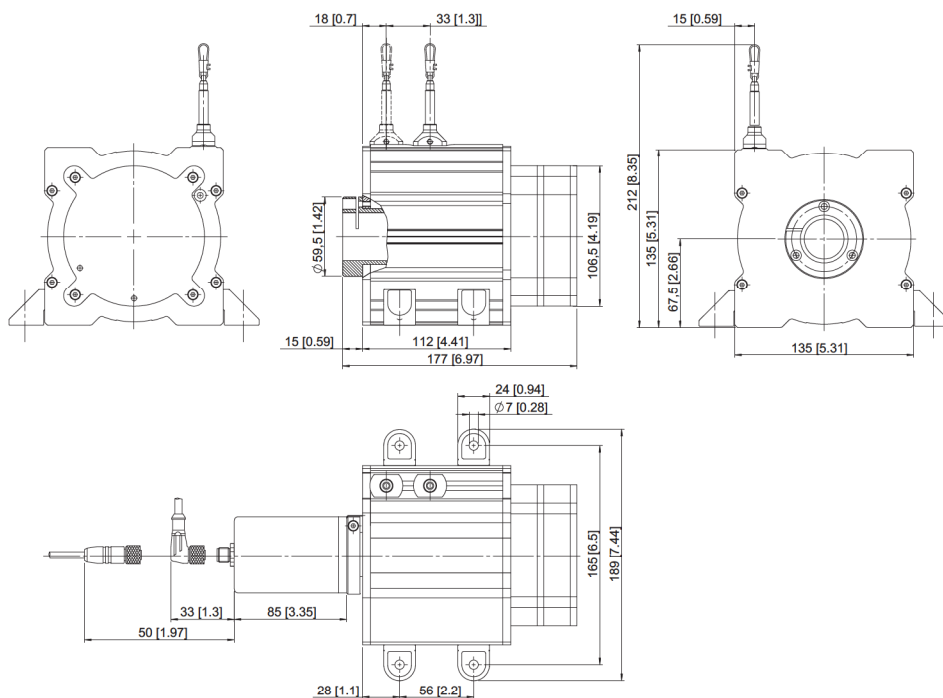

Linear Measuring Technology

Draw wire mechanics with encoder or analogue sensor

Draw wire encoder D135

Dimensions:

Draw wire mechanics with analogue sensor, measuring range 25000 ... 40000 mm

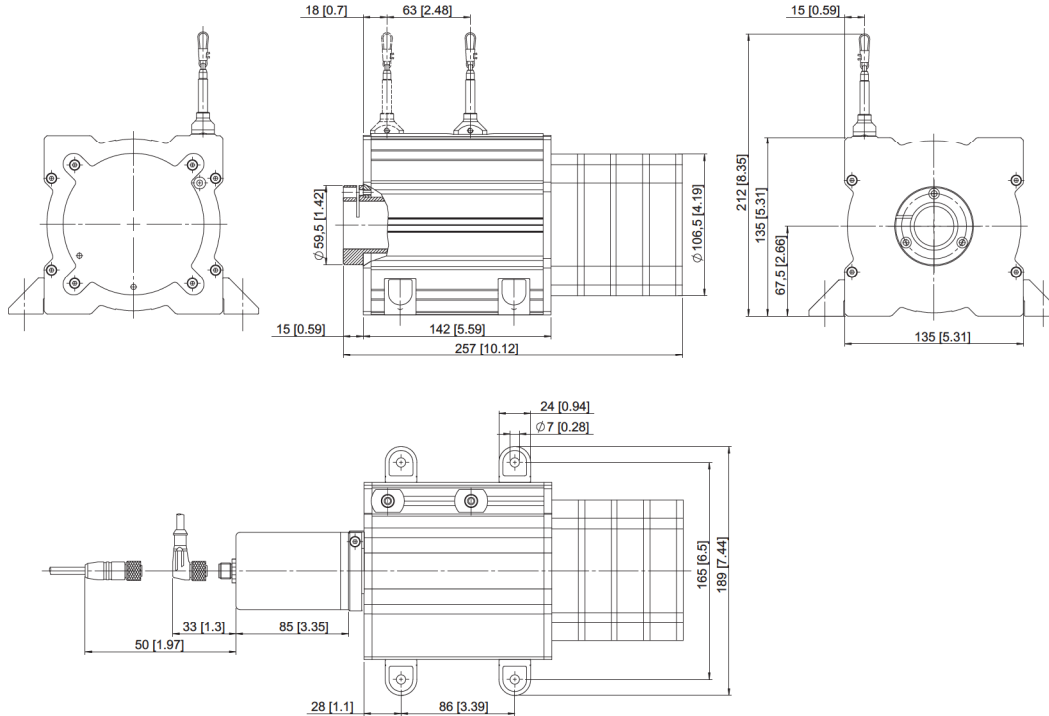

Order code with analogue sensor:

D8.3D1.XXXX.XXXX.0000

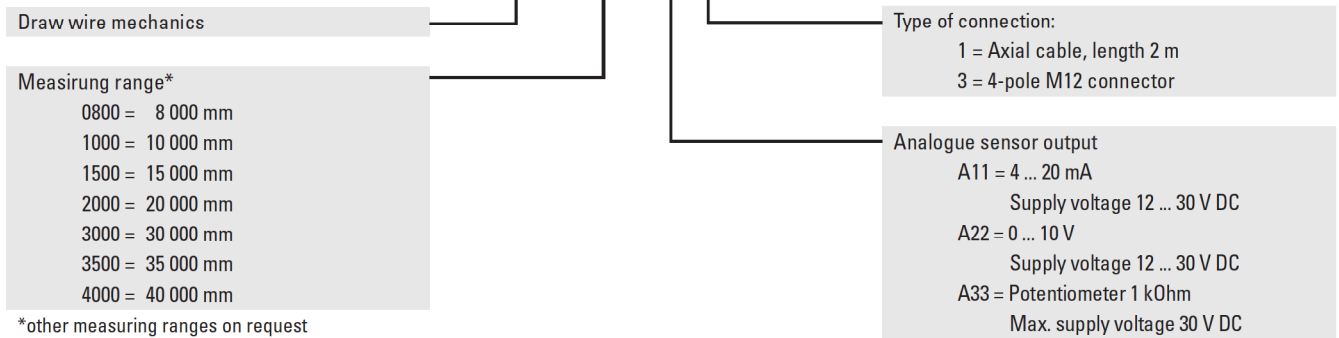

Accessories:

Guide pulley for draw-wire encoder



Order code for the set:
(Guide pulley, 2x countersunk screws for lateral fixing, 2x hexagonal screws for fixing on a flat surface)
8.0000.7000.0045

