

### S125L | LED 점등/점멸 표시등 LED Steady/Flashing Light



S125L

### 특수산광 그로브 채택으로 신호빛의 발산력 향상

- 고회도 LED 점등/점멸형
- 점등/점멸 선택 스위치 내장
- 광원의 수명이 반영구적, 진동 및 충격이 심한 기기에 적합
- 부저(Buzzer) 내장 가능. 음량 : Max.90dB/m \*2음 부저형은 주문제작
- 재질 : 그로브-AS, 몸체-ABS, 반사체-내열성 ABS
- 기술 인증 : CE
- 보호 등급 : IP44

- Product of steady/flashing, high-brightness LED type
- Having the built-in switch for steady/flashing selection
- Semi-permanent in the lifespan of light source and suitable for machines having lots of vibration and impact
- Option : buzzer applicable. Volume : Max.90dB/m
- Material : Lens-AS, Body-ABS, Reflector-Heat resisting ABS
- Certificate : CE
- Protection class : IP44

형식 Model	전압 Rated Voltage	전류 Current	중량 Weight	점멸수 Flashes Per Min.	색상 Color
S125L	DC12V	0.300A	0.30Kg	60~80	<ul style="list-style-type: none"> <li>■ 적-R</li> <li>■ 황-A</li> <li>■ 녹-G</li> <li>■ 청-B</li> </ul>
	DC24V	0.200A	0.30Kg		
	AC110V	0.060A	0.52Kg		
	AC220V	0.030A	0.52Kg		

### 외형도 (External view drawing)

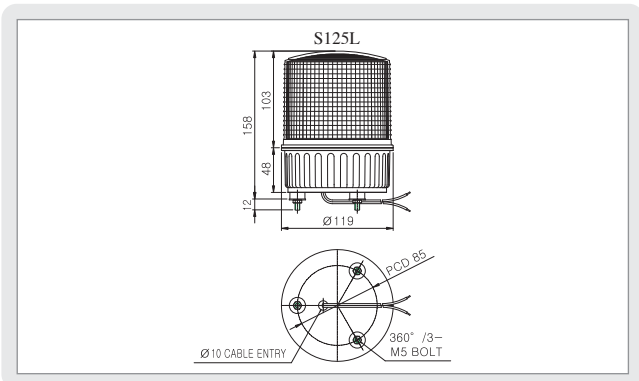

- 전원선 인출형 UL1015-NO.18(0.75sq)x2C 400mm
- DC 제품의 경우 흑색선이 (-)극성입니다.
- Power line out from the product UL1015-NO.18(0.75sq)x2C 400mm
- The black line of DC product is negative(-)

### S125 SERIES 사양지정(Order Specification)

#### • 부저 내장이 가능한 제품 (Buzzer Applicable)

S125R - (BZ) - 220 - R	부저(Buzzer)	전압(Voltage)	색상(Color)
· S125R	· 무지정(None)	· 12-DC12V	■ R-적(Red)
· S125U	Without Buzzer	· 24-DC24V	■ A-황(Amber)
· S125L	· BZ지정(Order)	· 110-AC110V	■ G-녹(Green)
· S125LR	With Buzzer	· 220-AC220V	■ B-청(Blue)
· S125RLR			
· S125E			
· S125M			
· S125MLR			

#### • 부저 내장이 불가능한 제품 (Buzzer Inapplicable)

S125SM - 24 - A	전압(Voltage)	색상(Color)
· S125S	· 12-DC12V	■ R-적(Red)
· S125HS	· 24-DC24V	■ A-황(Amber)
· S125SM		■ G-녹(Green)
· S125HSM		■ B-청(Blue)

- ※ 초고회도 스트로브 제품인 HS형은 주문 제작 가능합니다.
- ※ High brightness strobe HS type is custom-made.

WARNING / SIGNAL LIGHT