

S150RL/S150RL-FT | LED 점등/점멸 표시등

LED Steady/Flashing Light



S150RL

S150RL-FT

산광 효과가 우수한 그로브 채택으로 시인성 향상

- 고휘도 LED 점등/점멸형
- 점등/점멸 선택 스위치 내장
- 광원의 수명이 반영구적, 진동 및 충격이 심한 기기에 적합
- S150RL-FT형은 취부 브라켓 부착형으로 설치가 간편
- 재질 : 그로브-PC, 몸체-SUS304, 반사체-내열성 ABS
- 보호 등급 : IP44
- Product of steady/flashing, high-brightness LED type
- Having a built-in switch for steady/flashing selection
- Product of S150RL-FT type is easily to be installed with fitting bracket attached
- Semi-permanent in the lifespan of light source and suitable for machines having lots of vibration and impact
- Material : Lens-PC, Body-SUS304, Reflector-Heat resisting ABS
- Protection class : IP44

형식 Model	전압 Rated Voltage	전류 Current	중량 Weight	점멸수 Flashes Per Min.	색상 Color
S150RL	DC12V	0.300A	0.64Kg	60~80	<ul style="list-style-type: none"> ■ 적-R ■ 황-A ■ 녹-G ■ 청-B
	DC24V	0.200A	0.64Kg		
S150RL-FT	AC110V	0.060A	0.92Kg		
	AC220V	0.030A	0.92Kg		

외형도 (External view drawing)

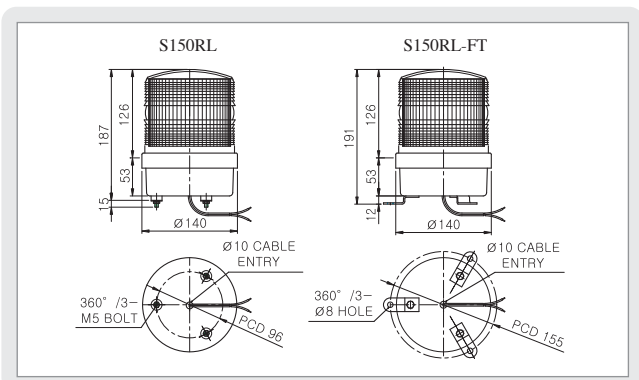

- 전원선 인출형 UL1015-NO.18(0.75sq)x2C 400mm
- DC 제품의 경우 흑색선이 (-)극성입니다.
- Power line out from the product UL1015-NO.18(0.75sq)x2C 400mm
- The black line of DC product is negative(-)

S150RHS/S150RHS-FT | 크세논램프 스트로브 라이트

Xenon Lamp Strobe Light



S150RHS

S150RHS-FT

초고휘도 스트로브 라이트, 장거리 시인성과 내구력 우수

- 크세논램프 스트로브형
- 컨넥터형의 램프 구조로 교체가 용이
- 점멸수 : 60~80/min.(2회 연속 섬광점멸)
- S150RHS-FT형은 취부 브라켓 부착형으로 설치가 간편
- 재질 : 그로브-PC, 몸체-SUS304
- 보호 등급 : IP44
- Xenon lamp strobe type
- Lamp of connector type whose replacement is easy
- Flashes : 60~80/min.(Continuous flashing of 2 times frequency)
- Product of S150RHS-FT type is easily to be installed with fitting bracket attached
- Material : Lens-PC, Body-SUS304
- Protection class : IP44

형식 Model	전압 Rated Voltage	전류 Current	중량 Weight	전구 Bulb	점멸수 Flashes Per Min.	색상 Color
S150RHS	DC12V	1.277A	0.78kg	49	60~80	<ul style="list-style-type: none"> ■ 적-R ■ 황-A ■ 녹-G ■ 청-B
	DC24V	0.655A	0.78kg			
S150RHS-FT	AC110V	0.233A	0.69kg			
	AC220V	0.186A	0.69kg			

외형도 (External view drawing)

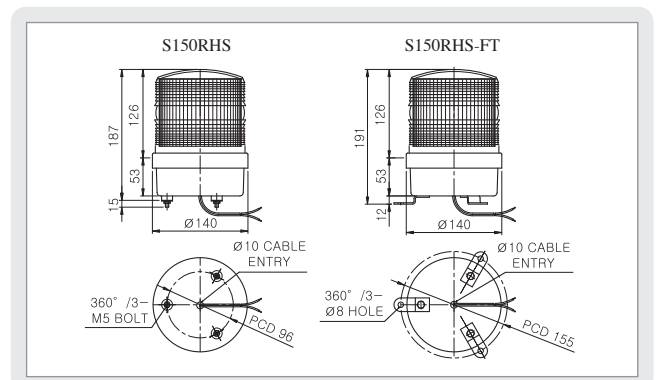

- 전원선 인출형 UL1015-NO.18(0.75sq)x2C 400mm
- DC 제품의 경우 흑색선이 (-)극성입니다.
- Power line out from the product UL1015-NO.18(0.75sq)x2C 400mm
- The black line of DC product is negative(-)