

SM

SERIES

모터 사이렌 Motor Siren



SM200 | 중부하용 모터사이렌

Heavy duty Motor Siren

알루미늄 하우징, 내구력이 우수한 고음량 중부하용 제품

- 내구력이 우수하고 음량이 높아 먼 거리 신호 전달력이 우수
- 각종 크레인, 선박, 화재경보 시스템의 경보 전달용으로 적합
- 몸체 표준 색상 : RED
- 재질 : DIECAST AI
- 절연저항 : 100MΩ (at 500 VDC)
- 내전압 : 500VAC, 50/60Hz in 1 minute • 보호 등급 : IP44
- High in durability and excellent in remote signal transmission due to high volume capacity
- Suitable for various types of cranes, vessels and fire warning systems
- Body standard color : RED
- Material : DIECAST AI
- Insulation resistance : 100M Ω (at 500 VDC)
- Dielectric strength : 500VAC, 50/60Hz in 1 minute
- Protection class : IP44



SM200

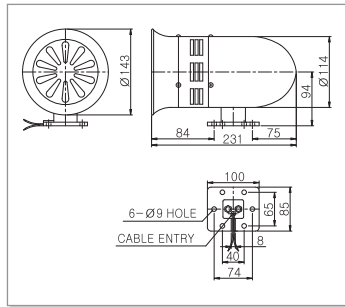

SM30/SM40 | 초소형 모터사이렌

Miniature Motor Siren

소형으로 고음량 출력, 소형기계의 위험 신호 전달에 적합

- 외경 80/100mm의 초소형으로 40W의 음량 출력
- 소형 호이스트, 경량 대차, 소형 선박의 선내 경보 전달용으로 적합
- 몸체 표준 색상 : RED(SM30) & GRAY(SM40)
- 재질 : Steel(SM30) & ABS(SM40)
- 절연저항 : 100MΩ (at 500 VDC)
- 내전압 : 500VAC, 50/60Hz in 1 minute • 보호 등급 : IP44
- Miniature Motor Siren with the external diameter of 80/100mm which makes the output of 40W sound volume
- Suitable for warning information of small hoist, light transfer cars and the inside of small vessel
- Body standard color : RED(SM30) & GRAY(SM40)
- Material : STEEL(SM30) & ABS(SM40)
- Insulation resistance : 100M Ω (at 500 VDC)
- Dielectric strength : 500VAC, 50/60Hz in 1 minute
- Protection class : IP44



SM30

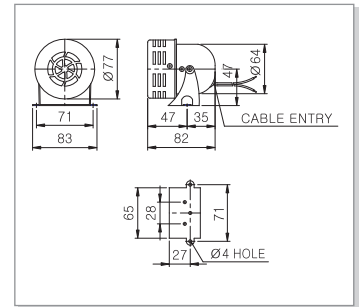

형식 Model	음량 dB/m (Max)	전압 Rated Voltage	전류 Current	중량 Weight	회전수 RPM	정격 Rating
SM30	110dB	DC12V	6.00A	0.29Kg	10,000	10MIN.
		DC24V	2.50A	0.29Kg		
		AC110V	0.90A	0.55Kg		
		AC220V	0.43A	0.55Kg		
SM40	116dB	DC12V	5.80A	0.54Kg	7,000	10MIN.
		DC24V	2.10A	0.54Kg		
		AC110V	1.60A	0.69Kg		
		AC220V	0.80A	0.69Kg		
SM200	120dB	DC12V	12.40A	2.19Kg	7,200	10MIN.
		DC24V	6.80A	2.19Kg		
		AC110V	1.50A	2.72Kg		
		AC220V	1.00A	2.72Kg		
SM400	123dB	DC12V	16.40A	3.45Kg	7,600	10MIN.
		DC24V	8.80A	2.95Kg		
		AC110V	3.40A	3.45Kg		
		AC220V	1.60A	3.45Kg		



SM40

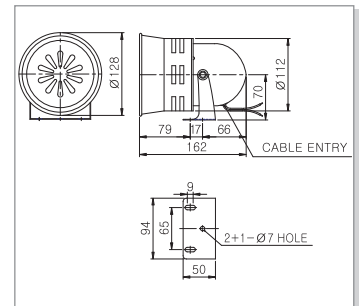

SM400 | 중부하용 모터사이렌

Heavy duty Motor Siren

알루미늄 하우징, 내구력이 우수한 고음량 중부하용 제품

- 내구력이 우수하고 음량이 높아 먼 거리 신호 전달력이 우수
- 각종 크레인, 선박, 화재경보 시스템의 경보 전달용으로 적합
- 몸체 표준 색상 : RED • 재질 : DIECAST AI
- 절연저항 : 100MΩ (at 500 VDC)
- 내전압 : 500VAC, 50/60Hz in 1 minute • 보호 등급 : IP44
- High in durability and excellent in remote signal transmission due to high volume capacity
- Suitable for various types of cranes, vessels and fire warning systems
- Body standard color : RED • Material : DIECAST AI
- Insulation resistance : 100M Ω (at 500 VDC)
- Dielectric strength : 500VAC, 50/60Hz in 1 minute
- Protection class : IP44

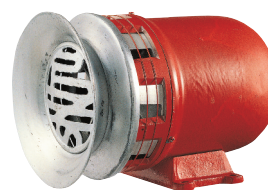

SM400

