

## 200W2(V1) Series

200W single output  
with constant voltage circuit



- Constant voltage design(C.V. mode)
- AC Input voltage 200-240V
- Protections:  
Overload/Over voltage /Short circuit
- IP68 design for outdoor installations
- 100% full load burn-in test
- Suitable for LED lighting and moving sign applications
- Metal case
- Safety standards :  
EN61347-1,EN61347-2-13/K61347-1, K61347-2-13
- EMC standards :  
EN61204-3,EN61000-3-2,3/  
K00015,K61547,K61000-4-2, 3,4,5,6,11
- 3years warranty

IP68

ITEM		UP200S12W2(V1)	UP200S24W2(V1)
INPUT	VOLTAGE RANGE	AC200~240V	
	FREQUENCY RANGE	47~63Hz	
	EFFICIENCY(typ.)	85%	88%
	AC CURRENT(typ.)	1.44A/220VAC	
	INRUSH CURRENT(typ.)	COLD START 70A/220VAC	
	LEAKAGE CURRENT	<2.5mA / 220VAC	
OUTPUT	DC VOLTAGE	12V	24V
	RATED CURRENT	16.6A(12.49A@50°C)	8.33A(6.24A@50°C)
	RATED POWER	200W	200W
	RIPPLE&NOISE(max.) Note2	170mVp-p	290mVp-p
	VOLTAGE ADJ. RANGE	±5%	±5%
	VOLTAGE TOLERANCE Note3	±3%	±3%
	LINE REGULATION Note4	±1%	±1%
	LOAD REGULATION Note5	±2%	±2%
	SETUP,RISE TIME(typ.)	600ms,40ms/220VAC at full load	
	HOLD UP TIME(typ.)	15ms/220VAC at full load	
PROTEC-TION	SHORT CIRCUIT	Hiccup mode ; recovers automatically after fault condition is removed	
	OVERLOAD	Over 110% of rating ; recovers automatically after fault condition is removed	
	OVER VOLTAGE	115~140% of rating	
ISOLA-TION	WITHSTAND VOLTAGE	I/P-O/P:AC3KV, I/P-F.G:AC1.5KV, O/P-F.G:AC0.5KV	
	ISOLATION RESISTANCE	I/P-O/P, I/P-F.G, O/P-F.G:DC500V 100Mohms(At room temp. & humid.)	
ENVIRON-MENT	WORKING TEMP.&HUMID.	-30~+50°C(Refer to "DERATING CURVE"),20~95%RH	
	STORAGE TEMP.&HUMID.	-40~+75°C,10~95%RH	
	VIBRATION	10~500Hz, 5G 12min./1cycle, period for 72min. each along X, Y, Z axes	
OTHERS	DIMENSION	230*74*46.5mm(L*W*H)	
	PACKING	1.1Kg	

**NOTE**

1. All parameters not specially mentioned are measured at 220vac input, rared load and 25°C of ambient temperature.
2. Ripple & noise are measured at 20MHz of bandwidth by using a 12" twisted pare-wire terminated with 0.1 uF & 47uF parallel capacitor.
3. Tolerance : includes set up toltrance, line regulation and load regulation.
4. Line regulation is measured from low line to high line at rated load.
5. Load regulation is measured from low 0% to 100% rated load.

S.M.P.S

LED Converter

Water Proof Converter

■ BLOCK DIAGRAM

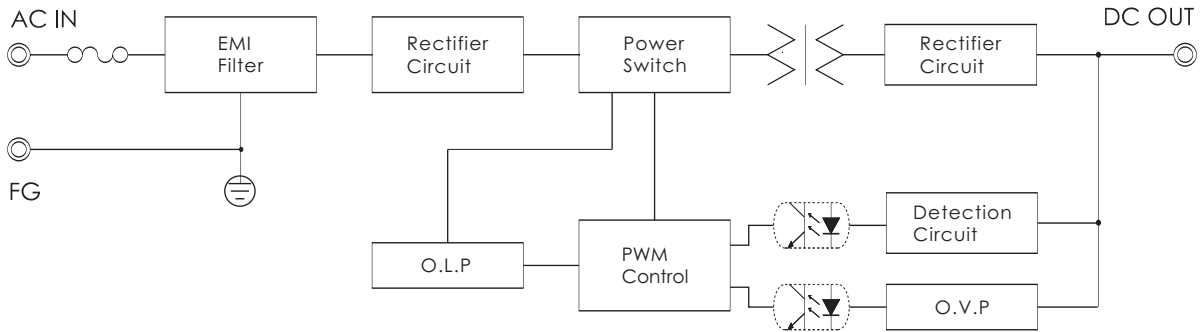

■ DIMENSIONS(unit:mm)

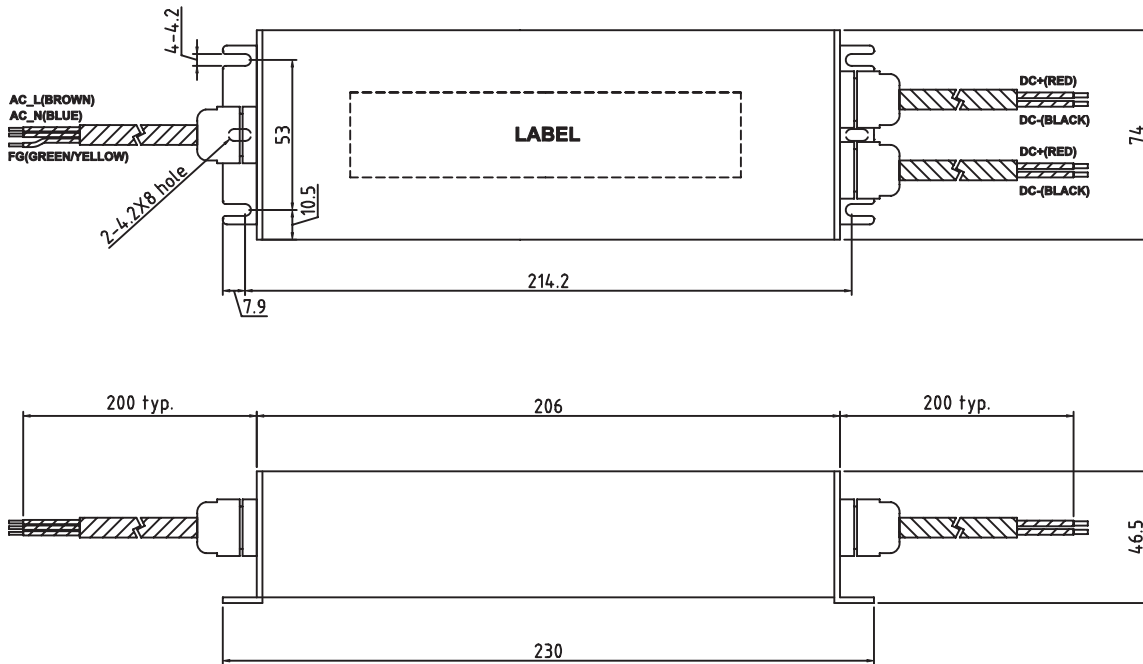

■ DERATING CURVE

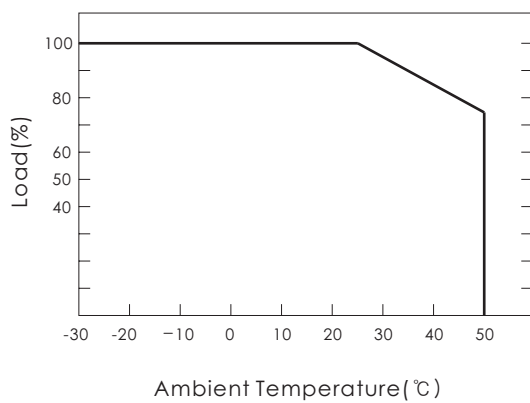

■ STATIC CHARACTERISTICS

